

C-A/AP/#315
July 2008

Capacitive fundamental power coupler and pickup for the 56 MHz SRF cavity

E. M. Choi and H. Hahn



**Collider-Accelerator Department
Brookhaven National Laboratory
Upton, NY 11973**

Capacitive fundamental power coupler and pickup for the 56 MHz SRF cavity

E. M. Choi and H. Hahn

July 16, 2008

Abstract

The beam excited 56 MHz SRF cavity will have a power coupler for a fast frequency tuner. The calculation shows the coupling of the power coupler, β_{opt} , is around 50. Size and location of the power coupler are determined by measurements. Measurements are in good agreement with the simulation results. The axial location of the power coupler for the Nb cavity is limited by corrugations made on the cavity outer conductor for purpose of removing any multipacting. The preferred axial location is 14.5 cm away from the cavity gap start where a slow tuner plate will be. MWS simulations are done to determine the length of the power coupler inner conductor and pickup probe for the Nb cavity at the fixed axial location. Size and location of both the fundamental power coupler and the pickup probe can be decided from the simulation results.

1 Introduction

The 56 MHz Superconducting cavity is going to be installed in RHIC for enhancing the luminosity. Table 1 shows the cavity parameters of the SRF 56 MHz cavity. A 1 kW of power amplifier is chosen for a fast frequency tuning, which is capable of providing ± 0.75 Hz frequency tuning range for compensating microphonics. The power coupler will be capacitively coupled near the cavity gap region. The required coupling factor for the fundamental power coupler (FPC) was β_{opt} of 50 calculated by Ilan Ben-Zvi, which in turn corresponds to Q_{ext} of 4×10^7 assuming Q_0 is 2×10^9 .

As for a pickup probe (PU), 1 W power coming out from the pickup probe will be enough for output signal which corresponds to external Q of 8×10^{10} . Size and location of both the FPC and the PU are determined by measurements and also the results are compared to simulation results for projecting it onto the Nb cavity case.

Table 1: Summary of the 56 MHz SRF cavity parameters

Parameter	Values
Frequency	56.25 MHz
Voltage	2.5 MV
Superconducting surface resistance	10 n Ω
Power dissipated to LHe (4.2 K)	42 W
Q factor	1.8×10^9
Stored energy	221 J (From MWS)
R over Q (accelerator definition)	79.9 (From MWS)

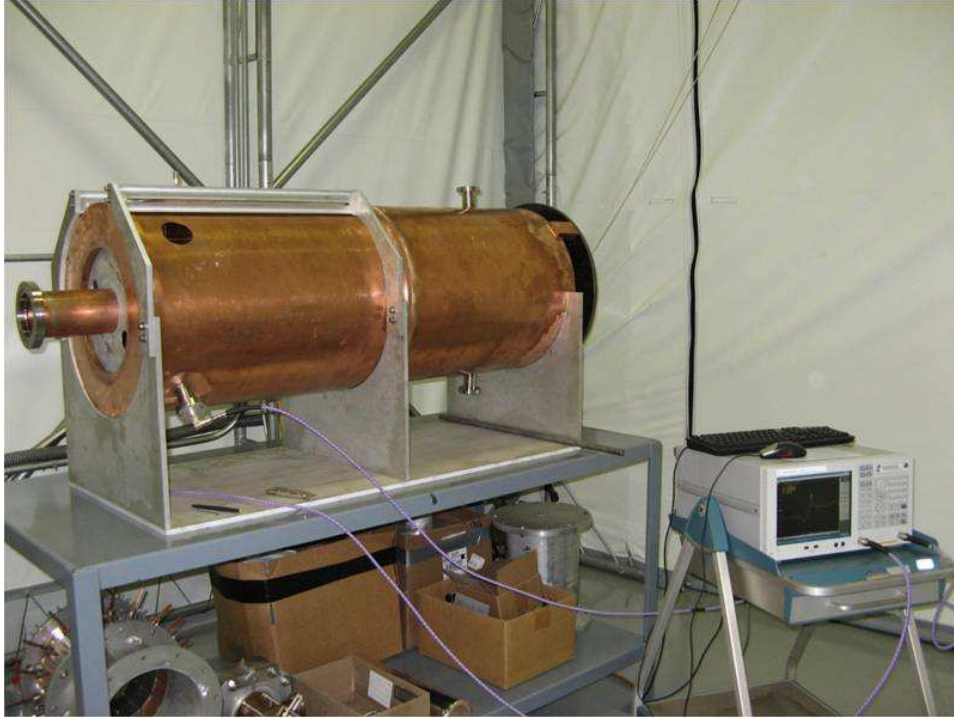

Figure 1: The experimental setup of the Cu prototype cavity

2 Experimental setup

Fig. 1 shows the measurement setup for the Cu prototype cavity with a Vector Network Analyzer (Agilent E5071C, 9 kHz-8.5 GHz, ENA Series Network Analyzer). Measurements on the Cu prototype for the FPC and the PU were done in the pickup probe ports of the prototype cavity, which are 20 cm away from the cavity gap start. The schematic of the prototype Cu cavity is shown in Fig. 2. The diameter of the FPC probe is 1.52 cm for the test and the length of the FPC probe is varied so that the position for giving the required external Q can be searched.

3 The interpretation of external Q measurements via scattering parameters

The measurements were done in two different ways. One uses S_{11} measurement and the other uses S_{21} with an network analyzer. If the coupling between the cavity and the load is not too small to pick up some signal, S_{11} measurements can be used to obtain external Q factor accurately enough. Fig. 3 shows the circuit representation of the cavity with external loads using the ideal transformer. Here, the external loads are vector network analyzer input and output ports. The circuit components are normalized. X equals to

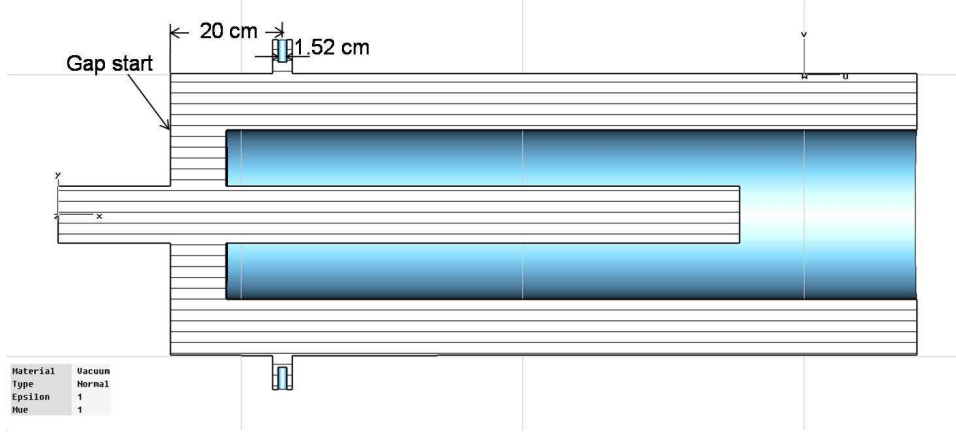

Figure 2: A drawing of the prototype cavity with PU probes. The gap start is specified in the drawing where the slow tuner will be.

$(\omega/\omega_0 - \omega_0/\omega)$. Fig. 4 is the equivalent circuit of Fig. 3 referred to the middle loop. The S_{21} is defined as

$$S_{21} = \frac{2V_2}{V_0}. \quad (1)$$

The current i in Fig. 4 can be expressed as follows.

$$\sqrt{\beta_{in}}V_0 = i \cdot \left[\frac{\beta_{in}}{Q_0} + \frac{1}{Q_0} + jX + \frac{\beta_{out}}{Q_0} \right] = i \cdot \left[\frac{1}{Q_L} + jX \right] \quad (2)$$

Here, $\frac{1}{Q_L} = \frac{1}{Q_0} + \frac{\beta_{in}}{Q_0} + \frac{\beta_{out}}{Q_0}$. V_2 expression can be related to the current i showing in Eq. 3.

$$\sqrt{\beta_{out}}V_2 = \frac{\beta_{out}}{Q_0} \cdot i \quad (3)$$

Using Eq. 2 and Eq. 3, S_{21} defined in Eq. 1 can now become as follows.

$$S_{21} = \frac{2\sqrt{\beta_{in}}\sqrt{\beta_{out}}}{Q_0 \left(\frac{1}{Q_L} + jX \right)} \quad (4)$$

Knowing that $\beta_{in} = Q_0/Q_{in}$ and $\beta_{out} = Q_0/Q_{out}$, one can construct S_{21} as follows.

$$S_{21} = \frac{2Q_L}{\sqrt{Q_{in}Q_{out}}(1 + jXQ_L)} \quad (5)$$

At critically coupled case, Q_{ext} equals to Q_0 . Therefore, Q_L is half of Q_0 . One can find external Q factor by measuring S_{21} using the following equation from Eq. 5 at critically coupled case ($Q_L=Q_0/2$, $Q_{in}=Q_0$, and $Q_{out}=Q_{ext}$) at resonance ($X=0$).

$$Q_{ext} = \frac{Q_0}{S_{21}^2} \quad (6)$$

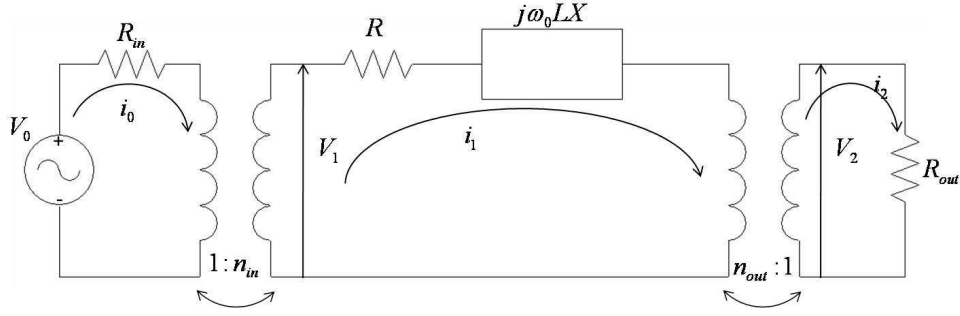

Figure 3: The equivalent circuit representation of the cavity with an ideal transformer

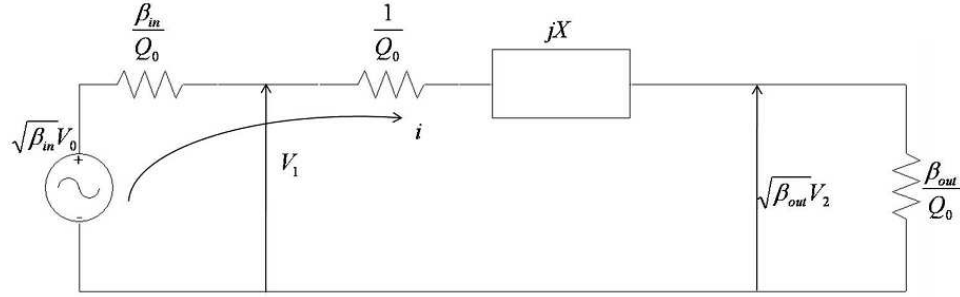

Figure 4: The equivalent circuit representation of the cavity referred to the middle cavity loop

Eq. 6 is a direct expression for obtaining Q_{ext} from the S_{21} measurements. S_{11} can be expressed as follows.

$$S_{11} = \frac{R + j\omega_0 LX - Z_0}{R + j\omega_0 LX + Z_0} = \frac{1 - \beta_{in} + \beta_{out} + jXQ_0}{1 + \beta_{in} + \beta_{out} + jXQ_0} \quad (7)$$

One can get β_{out} from the S_{11} measurement at resonance. In the measurement, we have $\beta_{in}=0$ by having the pickup port open. Therefore, the coupling of the power coupler to the cavity is now easily obtained from S_{11} .

$$\beta_{out} = \frac{Q_0}{Q_{ext}} \quad (8)$$

Eq. 8 gives Q_{ext} value. However, if the coupling gets too weak, the S_{11} does not give an accurate measurement. A more accurate measurement is directly using S_{21} parameter at critically coupled β_{in} .

4 The Fundamental power coupler study

The critically coupled case was achieved by having a proper size of the probe and penetration to the cavity. The probe whose diameter is 0.64 cm is 3.8 cm penetrated into the cavity and it has a 3.18 cm diameter disk on the top of the probe. The measured Q_0

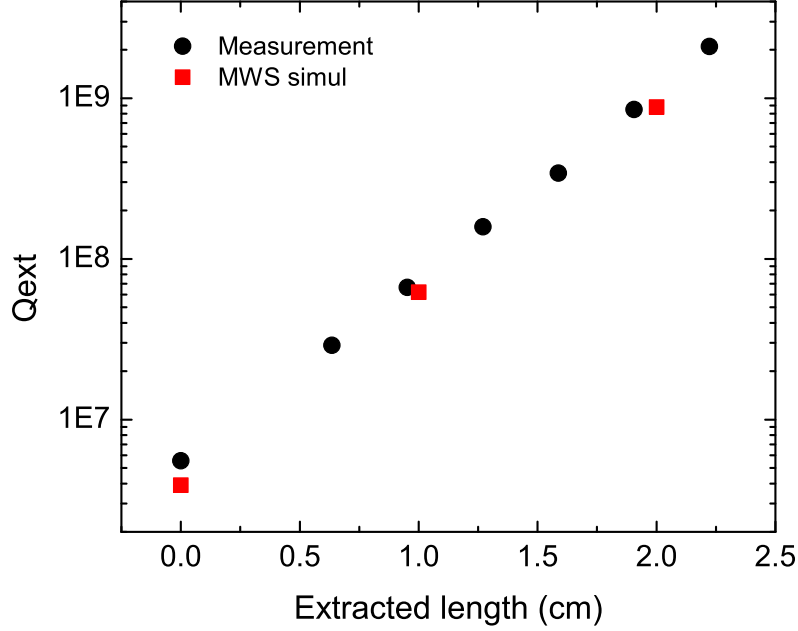

Figure 5: Experimental external Q values compared to the MWS simulation results. Black circle represents experimental data and red rectangles represent simulation data.

is approximately 8400 for the Cu prototype. For the test of the FPC, the length of the FPC probe was varied while the diameter is fixed to be 1.52 cm as shown in Fig. 2.

Fig. 5 shows the result of external Q measurement compared to the MWS simulation results modeled as shown in Fig. 2. The length of the FPC inner conductor was varied and the tip of the FPC inner conductor was extracted to the outside of the cavity for each point because even at no penetration Q_{ext} value is much smaller than the required Q_{ext} . As shown in the Fig. 5, the experimental data matches very well to the simulation data by MWS. The Q_{ext} of 4×10^7 is achieved around 1 cm extracted length.

The measurement was made at 20 cm away from the gap start of the prototype Cu cavity. The planned location for the FPC is at either the center of the cavity gap or 14.5 cm away from the gap start in the Nb SRF cavity. In order to circumvent possible cryogenic design difficulties, 14.5 cm away from the gap start is a better location for the FPC as shown in Fig. 6. The 14.5 cm location is determined such that the FPC can be situated between the first corrugation and the next corrugation (corrugation of the outer conductor is applied in order to prevent multipacting.). Since the prototype cavity does not have an open coupler port for various axial locations, the MWS simulation study determines the port size and the length of the FPC (Notice that the simulation data agrees well to the experiment as shown in Fig. 5.). The size of the port for the new FPC location is limited by the corrugations of the cavity surface and the maximum opening

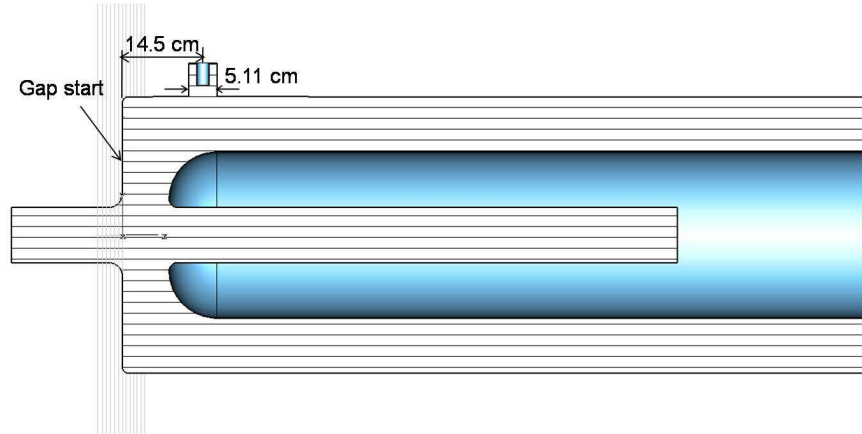

Figure 6: A drawing of the Nb cavity with a FPC.

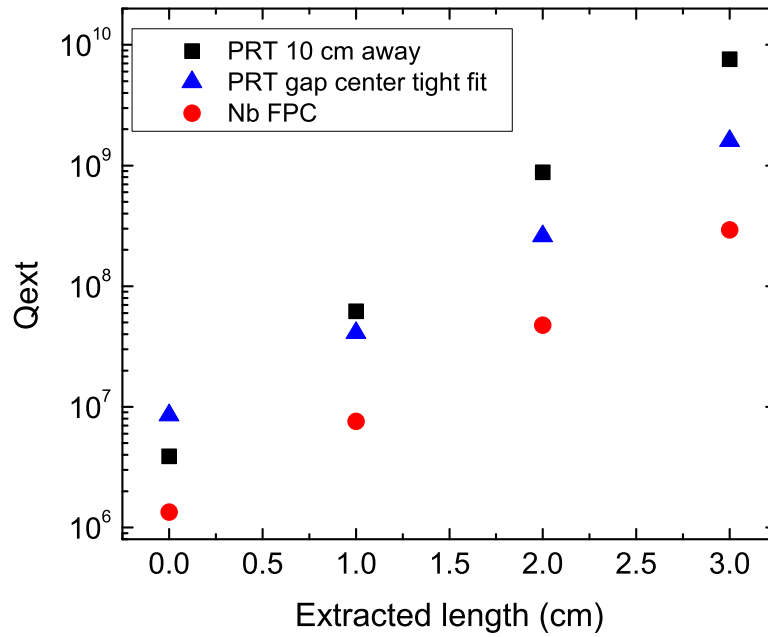

Figure 7: Simulation study on the external Q values. Black circle, blue triangle, and red circle represent MWS simulation of current setup, simulation of a new location at the gap center with a maximum port size and Nb cavity with a new location and a maximum port size, respectively.

for the FPC port is 5.11 cm. The FPC probe size is determined to be 2.21 cm obtained from the 50Ω relationship.

Fig. 7 shows the MWS simulation study on the external Q values as the FPC size and length are varied. When the FPC is at the gap center of the prototype cavity with the diameter of the probe of 2.21 cm, 1 cm extraction will give the desired Q_{ext} . Projection onto the Nb SRF cavity is made in Fig. 7 with red circles. The FPC is located 14.5 cm away from the gap start, and the FPC probe diameter is 2.21 cm. 2 cm extraction will result in the target external Q of 4×10^7 . It should be pointed out that the capacitively coupled FPC probe has a feature that allows the extraction length to be variable so that it is capable of changing the coupling between the cavity and the FPC in case of allowing higher FPC power to handle higher microphonics frequency than ± 0.75 Hz.

5 The Pickup Probe study

The size and length of the PU are determined based on the MWS simulation result. The PU is located at the same vertical plane as the FPC, which is 14.5 cm away from the gap start. The inner diameter of the PU port is chosen to be 1.9 cm, and the diameter of the PU probe is determined by 50Ω relationship with the PU port, which is 0.83 cm. Fig. 8 shows the external Q values as a function of the extracted length of the PU. From the simulation, the PU probe is to be extrated by around 2.5 cm from the cavity surface.

6 Conclusion

1 kW power coupler will act as a fast tuner. The location and the size of the fundamental power coupler are decided based on the measurements and simulations. The external Q of the power coupler from the calculation is 4×10^7 from the coupling β of 50. Measurements from the Cu prototype were made using the currently available pickup ports. The results were compared to the MWS simulation and give an excellent agreement between experiments and simulation. For the Nb SRF cavity, corrugations on the cavity outer cylinder, which are made to prevent possible multipacting, limit the possible FPC location. It is considered to be favorable to have the FPC 14.5 cm away from the gap start (Around the gap center, there will be a slow tuner and helium vessel, which will make somewhat complicated to have the power coupler in there.). From the MWS simulation, one can determine the length of the FPC probe in the Nb SRF cavity. The PU probe size and location can be also determined from the MWS result.

7 Acknowledgement

The authors would like to thank Ilan Ben-Zvi for calculation of the coupling factor for the FPC and reading the manuscript.

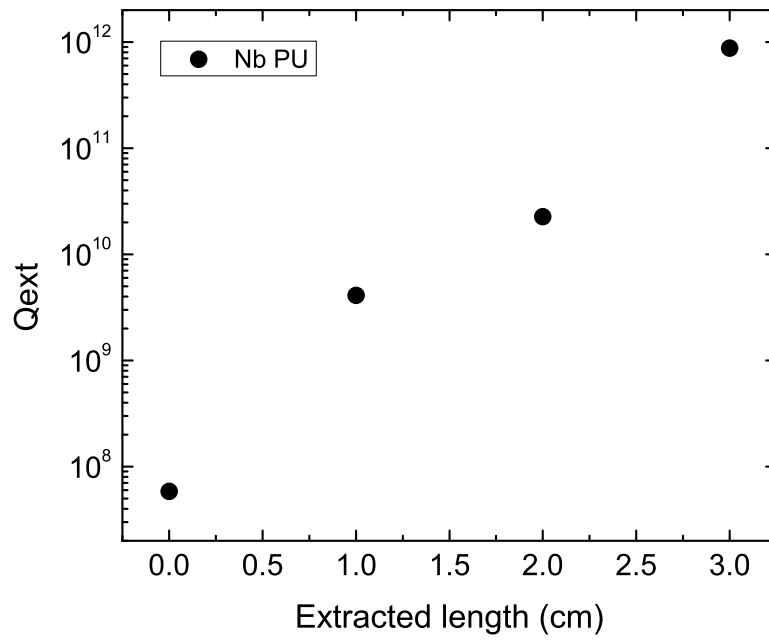

Figure 8: Simulation study on the PU probe.